

58CVA/CVX

INFINITY™ 80 VARIABLE SPEED

4-WAY MULTIPOISE FURNACE

Input Capacities: 70,000 thru 155,000 Btu/h



Turn to the Experts.™

Product Data

ComfortHeat. INFINITY SERIES IdealHumidity.

A04042

ISO 9001:2000

MEETS DOE RESIDENTIAL CONSERVATION SERVICES PROGRAM STANDARDS.

Before purchasing this appliance, read important energy cost and efficiency information available from your retailer.

THE INFINITY® 80 GAS FURNACE

The Infinity™ 80 Variable-Speed, 4-way Multipoise Gas Furnaces offer unmatched comfort with ComfortHeat™ technology and IdealHumidity™ in an 80% AFUE gas furnace. You get all the benefits of a ComfortHeat technology furnace: reduced drafts, reduced sound levels, longer cycles, less temperature swings between cycles, and less temperature differences between rooms. With the variable speed blower motor, homeowners can now economically run constant fan to help eliminate temperature differences throughout the house and to get better indoor air quality. This IdealHumidity furnace also increases comfort in the summer by wringing out extra humidity when needed. The Infinity 80 furnaces are approved for use with natural or propane gas, and the 58CVX is also approved for use in Low NOx Air Quality Management Districts.

Carrier Infinity™ System When the Infinity 80 variable-speed gas furnace is matched with the Infinity Control and an air conditioner or heat pump, you will experience the ultimate in ComfortHeat and Ideal Humidity through unparalleled control of temperature, humidity, indoor air quality, and zoning. The Carrier Infinity System also provides unprecedented ease of use through on-screen, text-based service reminders and equipment malfunction alerts.

For even greater comfort and convenience, match the Infinity 80 furnace with an Infinity air conditioner or heat pump. This will create a fully communicating system, requiring only 4 thermostat wires between system components, and troubleshooting can even be done in the future from the outdoor unit without entering the home.

Optional remote access through telephone or Internet is also available when combined with a remote connectivity kit.

STANDARD FEATURES

- Infinity™ System-match with the Infinity™ Control for Infinity™ System benefits
- ComfortHeat™ Technology Intelligent microprocessor control
- Two-stage heating with single-stage thermostat with patented Adaptive Control Technology

- Very low operating sound through low-stage operation and QuietTech™ system
QuietTech™ system noise reduction system
- Integral part of the IdealHumidity™ System
Maximum dehumidification selection for summer time cooling
Full IdealHumidity benefits including “Super Dehumidify”
SmartEvap™—Humidity control when using a Thermostat/Infinity control
Variable-speed blower motor
Super-low electrical use, up to 80 percent less than standard models
Increased SEER ratings for AC and HP systems

- Perfectly matches CFM to cooling system at all static points
- Comfort Fan™—Up to 12 cooling airflow selections from thermostat with a wide range of capability
- High-Efficiency Media Filtration Cabinet included
- Microprocessor based control center
LED diagnostics and self test feature
Stores fault codes during power outages
Adjustable heating air temperature rise
Adjustable cooling airflow
Dehumidification selection for summer-time cooling
- 4-way Multipoise furnace, 13 vent applications
- Compact design - only 33-1/3 in. tall

- Power Heat™ Igniter
- Draft Safeguard switch to ensure proper furnace venting
- Insulated blower compartment
- Inner door for tighter sealing
- Hybrid Heat™ compatible
- All models are chimney friendly when used with accessory vent kit
- Residential installations eligible for consumer financing through the Retail Credit Program

LIMITED WARRANTY

- 20-year warranty on “Super S™” heat exchanger
- 5-year parts warranty on all other components

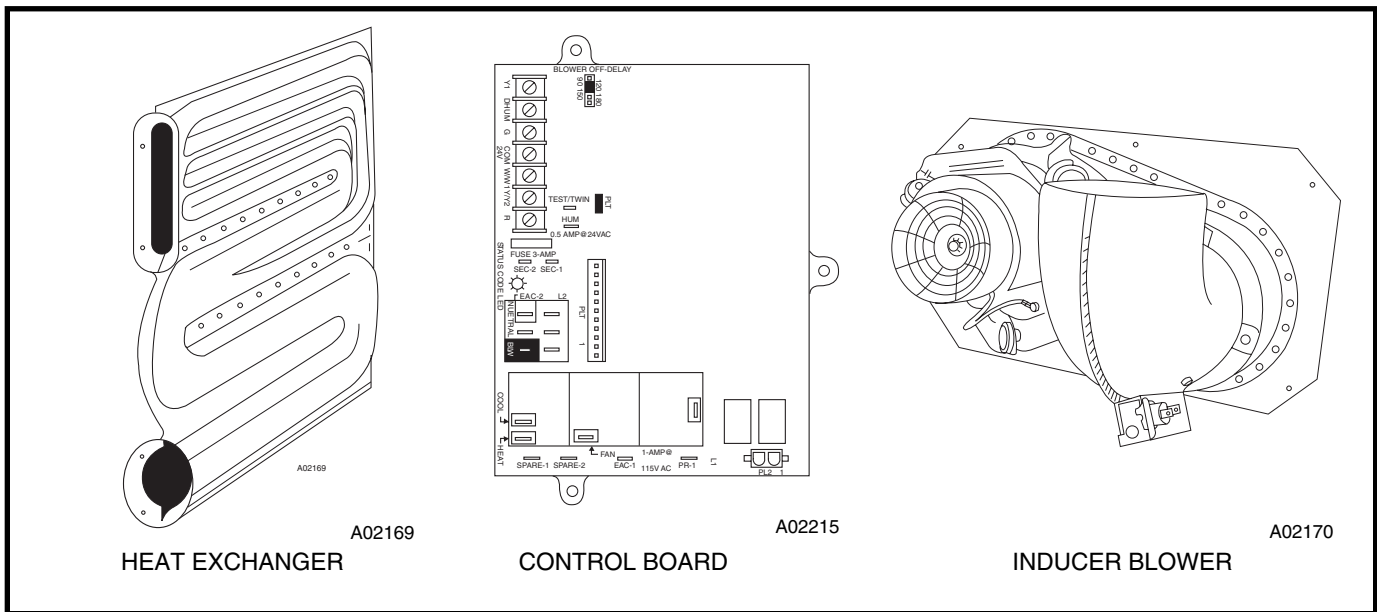

Model number nomenclature

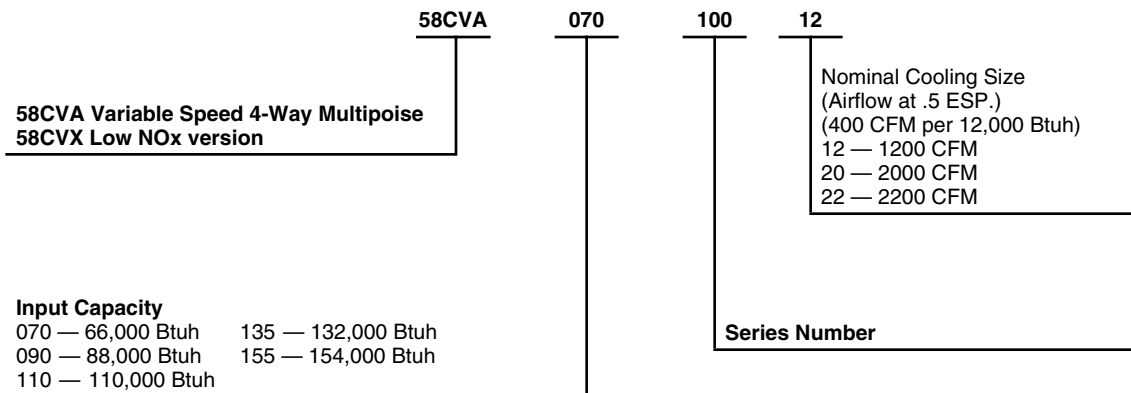

Furnace Components

58CVA/CVX

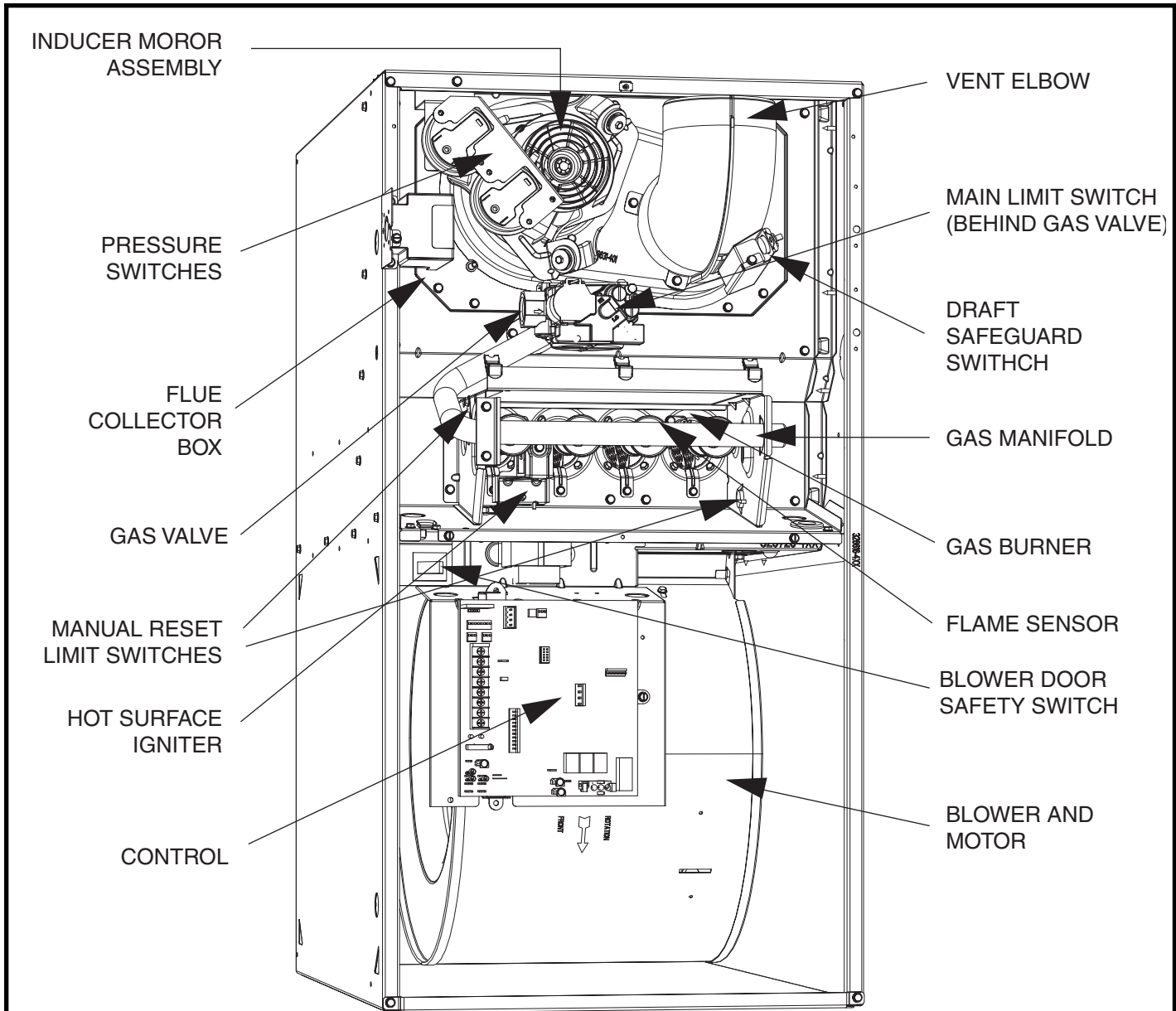

RATING PLATE
NOT SHOWN
(LOCATED ON
BLOWER DOOR)

A04137

*Elbow may be turned to a different position, depending on type of installation

NOTE: The 58CVA/CVX Furnaces are factory shipped for use with natural gas. These furnaces can be field-converted for propane gas with a factory-authorized and listed accessory conversion kit.

Carrier accessories

58CV(A)/CVX

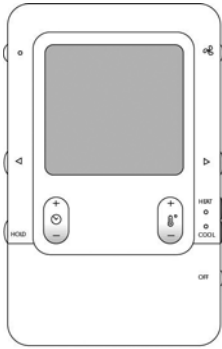

A03149

CONTROLS: THERMOSTATS AND ZONING

Available in programmable and non-programmable models, Carrier thermostats maintain a constant, comfortable temperature level in the home.

For the ultimate in home comfort, Carrier's 2, 4, and 8-zone systems allow temperature control of individual "zones" of the home. This is accomplished through a series of electronic dampers and remote room sensors. Infinity™ Control shown.

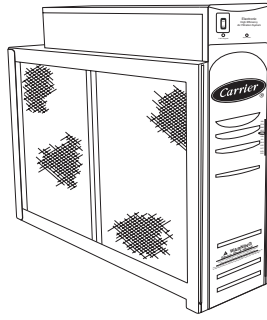

C04008

MECHANICAL OR ELECTRONIC AIR CLEANER

Cleans the air of smoke, dirt, and many pollens commonly found. Saves decorating and cleaning expenses by keeping carpets, furniture, and drapes cleaner.

Electronic air cleaner is shown.

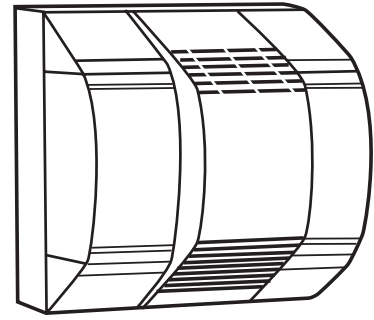

A01484

MODEL HUMCCLFP HUMIDIFIER

By adding moisture to winter-dry air, a Carrier humidifier can often improve comfort and keep furniture, rugs, and draperies in better condition. Moisturizing household air also helps to retain normal body heat and provides comfort at lower temperatures.

Accessories	
ELECTRONIC AIR CLEANER (EAC)	Model EACA
MECHANICAL AIR CLEANER	Models EZXCAB, FILCAB
HUMIDIFIER	Model HUM
HEAT RECOVERY VENTILATOR	Model HRV
ENERGY RECOVERY VENTILATOR	Model ERV
THERMOSTAT-NON-PROGRAMMABLE	Auto Changeover, °F/°C, 1-Stage Heat/1-Stage Cool - TSTATCCNAC01-B Auto Changeover, °F/°C, 2-Stage Heat/1-Stage Cool - TSTATCCNHP01-B Auto Changeover, °F/°C, 2-Stage Heat/2-Stage Cool - TSTATCCN2S01-B in AC Mode, 3-Stage Heat/2-Stage Cool in HP Mode Air Conditioner, 1-Stage Heat/1-Stage Cool, Manual Changeover, °F/°C - TSTATCCBAC01
THERMOSTAT-PROGRAMMABLE	Auto Changeover, 7-Day Programmable, °F/°C, 1-Stage Heat/1-Stage Cool-TSTATCCPAC01-B Auto Changeover, 7-Day Programmable, °F/°C, 2-Stage Heat/1-Stage Cool - TSTATCCPHP01-B Auto Changeover, 7-Day Programmable, °F/°C, 2-Stage Heat/1-Stage Cool - TSTATCCP2S01-B in AC Mode, 3-Stage Heat/2-Stage Cool in HP Mode Dual Fuel Thermostat Includes Outdoor Air Temperature Sensor -TSTATCCPDF01-B Thermostat Control - Non-Programmable/Programmable Thermostat -TSTATCCPRH01-B with Humidity Control (For use in Dual Fuel, AC, HP, and 2S applications, includes Outdoor Air Temperature Sensor)
ZONING - 2 ZONE	ZONE CC2KIT01-B, ZONE KIT2ZCAR
ZONING - 4 ZONE	ZONECC4KIT01-B
ZONING - 8 ZONE	ZONECC8KIT01-B
INFINITY CONTROL	Infinity™ Control Deluxe 7-Day Programmable (Wall-mounted system control.) - SYSTXCCUID01 Infinity™ Control Deluxe Zoning 7-Day Programmable (Wall-mounted control for a multi-zone system.) - SYSTXCCUIZ01 Infinity™ 4-Zone Damper Control Module (Wall-mounted for a 4-zone system.) - SYSTXCC4ZC02 Infinity™ Smart Sensor (Optional wall control used to monitor temperature and/or fan control in an individual zone.) - SYSTXCCSMS01 Infinity™ Remote Room Sensor (Monitors temperature in an individual zone.) - SYSTXCCRRS01 Infinity™ System Access Module (Hardware for wireless access and control via phone or internet.) - SYSTXCCSAM01 Infinity™ Network Interface Module (Connects Heat Recovery and Energy Recovery Ventilators or older two-speed outdoor models to system.) - SYSTCCNIM01† Decorative Back Plate for Infinity Control (Decorative wall plate.) - SYSTXXXBPU01

* When applied with Carrier's IdealHumidity series 58MVP, 58CV(A,X) and FE Indoor Models

† Must be installed in Dual-Fuel Infinity system applications.

Carrier Accessories

DESCRIPTION	PART NO.	070-12	090-16	110-20	135-22	155-22
Cartridge Media Filter	FILCCCAR0016	X	X			
	FILCCCAR0020			X		
	FILCCCAR0024				X	X
EZ Flex Media Filter with End Caps	EXPXXUNV0016	X	X			
	EXPXXUNV0020			X		
	EXPXXUNV0024				X	X
Replacement EZ Flex Filter Media	EXPXXFIL0016	X	X			
	EXPXXFIL0020			X		
	EXPXXFIL0024				X	X
External Bottom Return Filter Rack	KBAFR0401B14	X				
	KGAFR0501B17		X			
	KGAFR0601B21			X		
	KGAFR0701B24				X	X
External Side Return Filter Rack	KGAFR0801SRE	X	X	X	X	X
Unframed Filter 1-in.	KGAWF1306UFR	X	X	S†	S†	S†
	KGAWF1406UFR			X		
	KGAWF1506UFR				X	X
Flue Extension	KGAFE0112UPH	X	X	X	X	X
Combustible Floor Base	KGASB0201ALL	X	X	X	X	X
Downflow Vent Guard	KGAVG0101DFG	X	X	X	X	X
Vent Extension Kit	KGAVE0101DNH	X	X	X	X	X
Chimney Adapter Kit	KGACA02014FC	X	X	X		
Chimney Adapter Kit	KGACA02015FC				X	X
Natural-to-Propane Conversion Kit*	KGANP4001ALL	X	X	X	X	X
Propane-to-Natural Conversion Kit	KGAPN3301ALL	X	X	X	X	X
Label Kit	KGALB0101KIT	X	X	X	X	X
Air Leakage Kit (Qty 10)	KGBAC0110DGK	X	X	X	X	X
ECM Motor Simulator	KGASD0201FMS	X	X	X	X	X
Advanced Product Monitor	KGAFP0201APM	X	X	X	X	X
Gas Orifice Kit (Qty 50)	KGAHA0150N42					
	KGAHA0250N43 (factory supplied)					
	KGAHA0350N44					
	KGAHA0450N45					
	KGAHA0550N46					
	KGAHA1550N47					
	KGAHA1650N48					
	KGAHA0650P54					
KGAHA0750P55						

See Installation Instructions for model, altitude, and heat value usages.

* Factory-authorized, field installed. Fuel conversion kits are AGA/CGA recognized.

† Suitable for side return

58CVA/CVX

Physical data

58CVA/CVX

UNIT SIZE			070-12	090-16	110-20	135-22	155-22
OUTPUT CAPACITY BTUH* (Nonweatherized ICS) †	All 58CVA; 58CVX Upflow	High	54,000	71,000	89,000	107,000	125,000
		Low	35,000	47,000	59,000	70,000	82,000
	58CVX Downflow/Horizontal	High	51,000	68,000	85,000	102,000	119,000
		Low	35,000	47,000	59,000	70,000	82,000
INPUT BTUH*	All 58CVA; 58CVX Upflow	High	66,000	88,000	110,000	132,000	154,000
		Low	43,500	58,000	72,500	87,000	101,500
	58CVX Downflow/Horizontal	High	63,000	84,000	105,000	126,000	147,000
		Low	43,500	58,000	72,500	87,000	101,500
SHIPPING WEIGHT (lb)			127	151	162	177	183
CERTIFIED TEMP RISE RANGE (°F)		High	30-60	40-70	40-70	40-70	45-75
		Low	30-60	30-60	25-55	25-55	30-60
CERTIFIED EXT STATIC PRESSURE	Heating	High	0.12	0.15	0.20	0.20	0.20
	Cooling	Low	0.5	0.5	0.5	0.5	0.5
AIRFLOW CFM‡	Heating-High/Low		1180/735	1210/985	1475/1320	1915/1700	1970/1715
	Cooling		1225	1400	2095	2100	2095
AFUE%*	Nonweatherized ICS		80.0	80.0	80.0	80.0	80.0
LIMIT CONTROL					SPST		
HEATING BLOWER CONTROL					Solid-State Time Operation		
BURNERS (Monoport)			3	4	5	6	7
GAS CONNECTION SIZE					1/2-in. NPT		
GAS VALVE (Redundant) Manufacturer					White-Rodgers		
Minimum Inlet Pressure (In. wc)					4.5 (Natural Gas)		
Maximum Inlet Pressure (In. wc)					13.6 (Natural Gas)		
IGNITION DEVICE					Hot Surface		

* Gas input ratings are certified for elevations to 2000 ft. For elevations above 2000 ft, reduce ratings 4 percent for each 1000 ft above sea level. Refer to National Fuel Gas Code Table F4 or furnace Installation Instructions. In Canada, derate the unit 10 percent for elevations 2000 to 4500 ft above sea level.

† Capacity in accordance with U.S. Government DOE test procedures.

‡ Airflow shown is for bottom only return-air supply in comfort mode (as-shipped). For air delivery above 1800 CFM, see Air Delivery Table for other options. A filter is required for each return-air supply.

ICS — Isolated Combustion System

Blower performance data

UNIT SIZE	070-12	090-16	110-20	135-22	155-22
DIRECT-DRIVE MOTOR Hp (ECM)	1/2	1/2	1	1	1
MOTOR FULL LOAD AMPS	7.7	7.7	12.8	12.8	12.8
RPM (Nominal)	300-1300	300-1300	300-1300	300-1300	300-1300
BLOWER WHEEL DIAMETER × WIDTHS (In.)	10 x 6	10 x 8	11 x 10	11 x 11	11 x 11

ECM—Electronically Commutated Motor, Variable Speed

INSTALLATION

MINIMUM INCHES CLEARANCE TO COMBUSTIBLE CONSTRUCTION DISTANCE MINIMALE EN POUÇES AUX CONSTRUCTIONS COMBUSTIBLES

This forced air furnace is equipped for use with natural gas at altitudes 0-10,000 ft (0-3,050m).

An accessory kit, supplied by the manufacturer, shall be used to convert to propane gas use or may be required for some natural gas applications.

This furnace is for indoor installation in a building constructed on site.

This furnace may be installed on combustible flooring in alcove or closet at minimum clearance as indicated by the diagram from combustible material.

This furnace may be used with a Type B-1 Vent and may be vented in common with other gas fired appliances.

Cette fournaise à air pulsé est équipée pour utilisation avec gaz naturel et altitudes comprises entre 0-3,050m (0-10,000 pi).

Utiliser une trousse de conversion, fournie par le fabricant, pour passer au gaz propane ou pour certaines installations au gaz naturel.

Cette fournaise est prévue pour être installée dans un bâtiment construit sur place.

Cette fournaise peut être installée sur un plancher combustible dans une alcôve ou dans un garde-robe en respectant le minimum d'espace libre des matériaux combustibles, tel qu'indiqué sur le diagramme.

Cette fournaise peut être utilisée avec un conduit d'évacuation de Type B-1 ou connectée au conduit commun d'autres appareils à gaz.

This furnace is approved for UPFLOW, DOWNFLOW, and HORIZONTAL installations.

Cette fournaise est approuvée pour l'installation HORIZONTALE et la circulation d'air VERS LE HAUT et VERS LE BAS.

Clearance arrows do not change with furnace orientation.

Les flèches de dégagement ne change pas avec l'orientation de la fournaise.

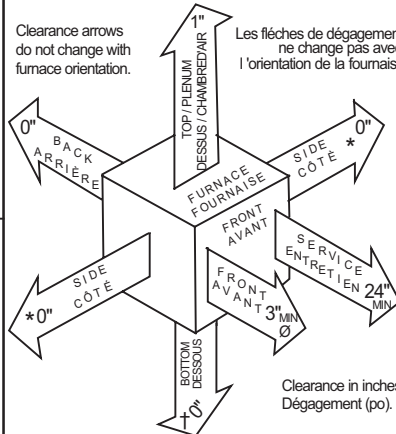

Vent Clearance to combustibles:

For Single Wall vents 6 inches (6 po).

For Type B-1 vent type 1 inch (1 po).

Dégagement de l'évent avec combustibles:

Pour conduit d'évacuation à paroi simple 6 po (6 inches).

Pour conduit d'évacuation de Type B-1 1 po (1 inch).

MINIMUM INCHES CLEARANCE TO COMBUSTIBLE CONSTRUCTION

DOWNFLOW POSITIONS:

† Installation on non-combustible floors only.

For Installation on combustible flooring only when installed on special base, Part No. KGASB0201ALL, Coil Assembly, Part No. CD5 or CK5, or Coil Casing, Part No. KCAKC.

Ø 18 inches front clearance required for alcove.

* Indicates supply or return sides when furnace is in the horizontal position. Line contact only permissible between lines formed by intersections of the Top and two Sides of the furnace jacket, and building joists, studs or framing.

DÉGAGEMENT MINIMUM EN POUÇES AVEC ÉLÉMENTS DE CONSTRUCTION COMBUSTIBLES

POUR LA POSITION COURANT DESCENDANT:

† Pour l'installation sur plancher non combustible seulement.

Pour l'installation sur un plancher combustible seulement quand on utilise la base spéciale, pièce n° KGASB0201ALL, l'ensemble serpentin, pièce n° CD5 ou CK5, ou le carter de serpentin, pièce n° KCAKC.

Ø Dans une alcôve, on doit maintenir un dégagement à l'avant de 18 po (450mm).

* La position indiquée concerne le côté d'entrée ou de retour quand la fournaise est dans la position horizontale.

Le contact n'est permis qu'entre les lignes formées par les intersections du dessus et des deux côtés de la cherrise de la fournaise et les solives, montant sous cadre de charpente.

327590-101 REV. C

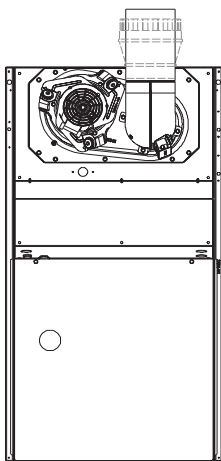

SEE NOTES: 1,2,4,7,8,9

UPFLOW

A02058

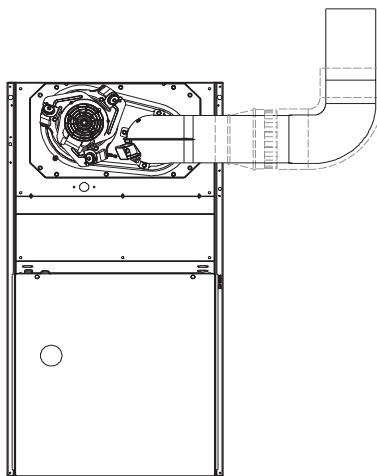

SEE NOTES: 1,2,3,4,7,8,9

UPFLOW

A02059

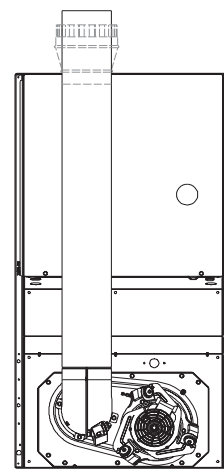

SEE NOTES: 1,2,4,5,7,8,9

DOWNFLOW

A02061

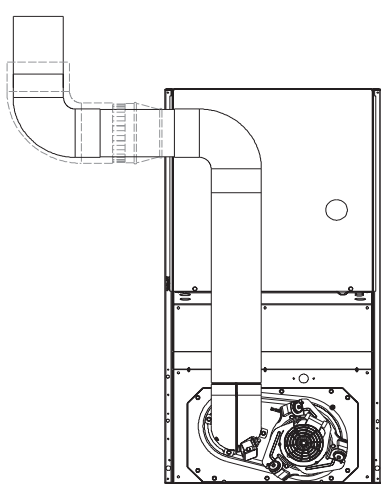

SEE NOTES: 1,2,3,4,5,7,8,9

DOWNFLOW

A02060

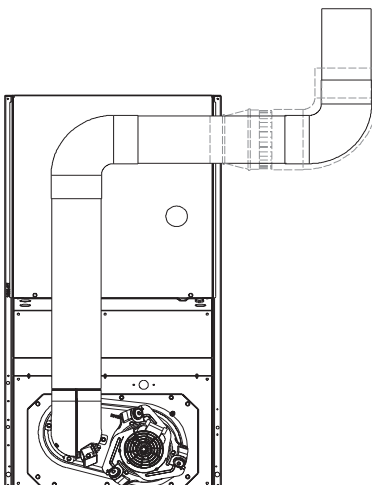

SEE NOTES: 1,2,3,4,5,7,8,9

DOWNFLOW

A02063

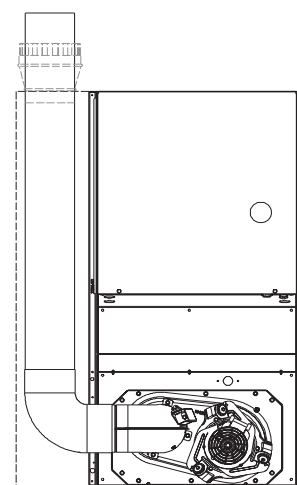

SEE NOTES: 1,2,4,5,6,7,8,9

DOWNFLOW

A02062

**Venting Notes**

1. For common vent, vent connector sizing and vent material: United States, latest edition of the National Fuel Gas Code (NFGC), ANSI Z223.1/NFPA 54. In Canada, latest edition of the National Standards of Canada, Natural Gas and Propane Installation Code (NSCNGPIC), CSA B149.1-00.
2. Immediately increase to 5-in. vent connector outside furnace casing when 5-in. vent connector required, refer to Note 1.
3. Side outlet vent for upflow and downflow installations must use Type B vent immediately after exiting the furnace, except when KGAVG0101DFG is used in downflow position.
4. Type B vent where required, refer to Note 1.
5. 4-in. single wall vent must be used inside furnace casing and the KGAVG0101DFG Downflow Vent Guard Kit.
6. Accessory Downflow Vent Guard Kit, KGAVG0101DFG required in downflow installations with bottom vent configuration.
7. Chimney Adapter Kit required for exterior masonry chimney applications. Refer to Chimney Adapter Kit, KGACA02014FC and KGACA02015FC for sizing and complete application details.
8. Secure vent connector to furnace elbow with (2) corrosion-resistant sheet metal screws, space approximately 180° apart.
9. Secure all other single wall vent connector joints with (3) corrosion-resistant screws spaced approximately 120° apart. Secure Type B vent connectors per vent connector manufacturer's recommendations.

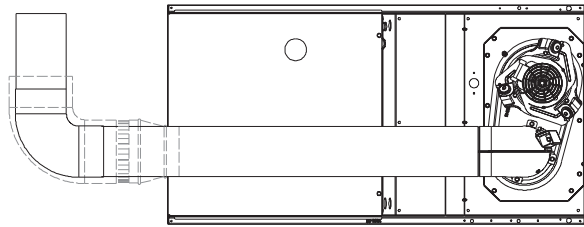

SEE NOTES: 1,2,4,5,7,8,9
HORIZONTAL RIGHT

A02068

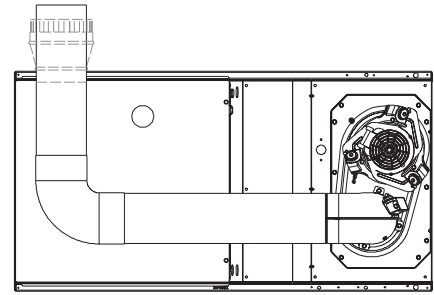

SEE NOTES: 1,2,4,5,7,8,9
HORIZONTAL RIGHT

A02070

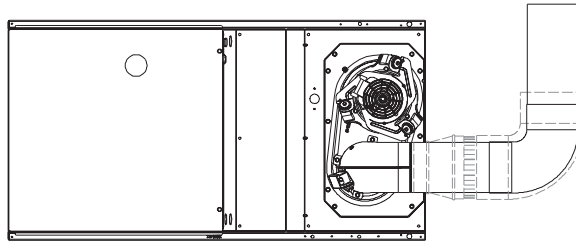

SEE NOTES: 1,2,4,7,8,9
HORIZONTAL RIGHT

A02069

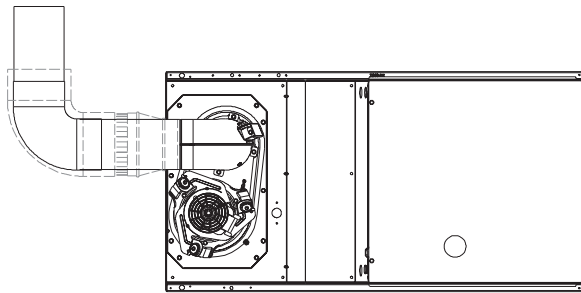

SEE NOTES: 1,2,4,7,8,9
HORIZONTAL LEFT

A02064

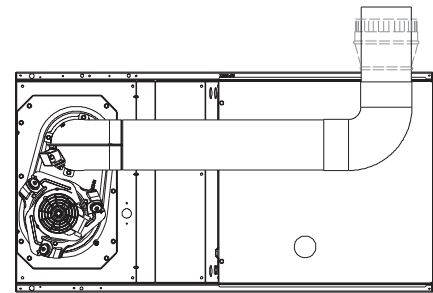

SEE NOTES: 1,2,4,5,7,8,9
HORIZONTAL LEFT

A02065

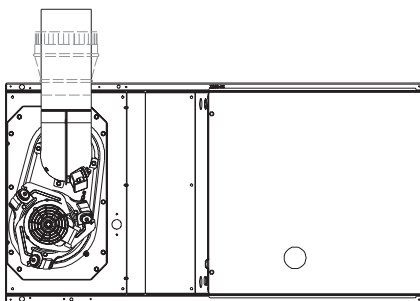

SEE NOTES: 1,2,4,5,7,8,9
HORIZONTAL LEFT

A02066

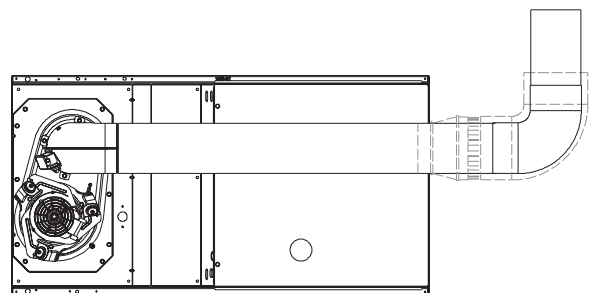

SEE NOTES: 1,2,4,5,7,8,9
HORIZONTAL LEFT

A02067

AIR DELIVERY- POWER DRAW (WATTS)**

Unit Size	Operating Mode	CFM Airflow Setting	External Static Pressure Range*	External Static Pressure (ESP)																		
				0.1	0.2	0.3	0.4	0.5	0.6	0.7	0.8	0.9	1.0									
070-12				AIRFLOW (CFM)																		
††	Low Heat	735 (615)†	0-0.50	735	735	735	735	725														
	High Heat	1180 (1060)†	0-1.0	1160	1165	1175	1180	1180	1180	1180	1180	1180	1180	1180	1175							
	†† 1-1/2 Ton Cooling	525	0-0.50‡	525	525	525	525	510														
	†† 2-Ton A/C Cooling	700	0-0.50‡	700	700	700	695	685														
	2-1/2 Ton A/C Cooling	875	0-1.0‡	875	875	875	875	875	875	865	855	845	840									
	3-Ton A/C Cooling	1050	0-1.0‡	1050	1050	1050	1050	1050	1050	1050	1050	1050	1045	1035								
	3-1/2 Ton A/C Cooling	1225	0-1.0	1205	1215	1225	1225	1225	1225	1225	1225	1225	1225	1225	1210							
	Maximum	1400	0-1.0	1395	1400	1400	1400	1400	1400	1400	1400	1400	1385	1360	1310							
090-16																						
††	Low Heat	985 (825)†	0-1.0	950	970	985	985	985	985	985	985	985	985	980								
	High Heat	1210 (1090)†	0-1.0	1190	1205	1210	1210	1210	1210	1210	1210	1210	1210	1200								
	†† 1-1/2 Ton A/C Cooling	525	0-0.50‡	525	525	525	525	500														
	†† 2-Ton A/C Cooling	700	0-0.50‡	690	695	700	700	690														
	2-1/2 Ton A/C Cooling	875	0-1.0‡	830	855	875	875	875	875	875	870	865	850	820								
	3-Ton A/C Cooling	1050	0-1.0‡	1005	1025	1040	1050	1050	1050	1050	1050	1050	1050	1050								
	3-1/2 Ton A/C Cooling	1225	0-1.0	1205	1220	1215	1225	1225	1225	1225	1225	1225	1225	1220								
	4-Ton A/C Cooling	1400	0-1.0	1370	1385	1395	1400	1400	1400	1400	1400	1400	1400	1380								
Maximum	1600	0-1.0	1565	1580	1585	1595	1600	1600	1600	1600	1560	1520	1480	1430								
110-20***																						
††	Low Heat	1320 (1110)†	0-1.0	1275	1295	1315	1320	1320	1320	1320	1320	1320	1320	1315								
	High Heat	1475 (1330)†	0-1.0	1460	1465	1475	1475	1475	1475	1475	1475	1475	1465	1465								
	†† 2-Ton A/C Cooling	700	0-0.50‡	700	700	700	700	685	660													
	†† 2-1/2 Ton A/C Cooling	875	0-0.50‡	860	875	865	855	840														
	†† 3-Ton A/C Cooling	1050	0-0.50‡	1050	1050	1045	1050	1050														
	3-1/2 Ton A/C Cooling	1225	0-1.0‡	1185	1195	1215	1225	1225	1225	1225	1225	1225	1225	1225								
	4-Ton A/C Cooling	1400	0-1.0‡	1385	1395	1400	1400	1400	1400	1400	1400	1400	1400	1400								
	5-Ton A/C Cooling	1750	0-1.0‡	1710	1730	1735	1745	1750	1750	1750	1750	1750	1745	1740								
6-Ton A/C Cooling	2100	0-1.0	2090	2100	2100	2100	2095	2085	2065	2045	2020	1990										
Maximum	2200	0-1.0	2200	2200	2200	2190	2185	2175	2155	2130	2085	2015										
135-22																						
††	Low Heat	1700 (1430)†	0-1.0	1700	1700	1700	1700	1700	1695	1700	1695	1685	1670									
	High Heat	1915 (1725)†	0-1.0	1900	1905	1915	1915	1915	1915	1915	1915	1915	1915									
	†† 2-Ton A/C Cooling	700	0-0.50‡	700	700	700	700	665														
	†† 2-1/2 Ton A/C Cooling	875	0-0.50‡	870	870	865	865	865														
	†† 3-Ton A/C Cooling	1050	0-0.50‡	1010	1030	1050	1050	1050														
	3-1/2 Ton A/C Cooling	1225	0-1.0‡	1155	1180	1200	1210	1220	1225	1225	1225	1225	1225									
	4-Ton A/C Cooling	1400	0-1.0‡	1395	1400	1400	1400	1400	1400	1400	1400	1390	1375	1355								
	5-Ton A/C Cooling	1750	0-1.0‡	1740	1750	1750	1750	1735	1740	1735	1730	1715	1700									
6-Ton A/C Cooling	2100	0-1.0	2075	2085	2090	2100	2100	2100	2100	2090	2080	2055	2025									
Maximum	2200	0-1.0	2180	2195	2200	2200	2200	2200	2200	2185	2165	2140	2095									
155-22																						
††	Low Heat	1715 (1440)†	0-1.0	1715	1715	1715	1715	1715	1705	1710	1705	1705	1695									
	High Heat	1970 (1775)†	0-1.0	1955	1965	1965	1970	1970	1970	1970	1970	1970	1960									
	†† 2-Ton A/C Cooling	700	0-0.50‡	700	700	700	700	680														
	†† 2-1/2 Ton A/C Cooling	875	0-0.50‡	865	875	875	865	865														
	†† 3-Ton A/C Cooling	1050	0-0.50‡	1015	1020	1035	1045	1050														
	3-1/2 Ton A/C Cooling	1225	0-1.0‡	1160	1185	1215	1225	1225	1225	1225	1225	1225	1225									
	4-Ton A/C Cooling	1400	0-1.0‡	1385	1400	1400	1400	1400	1400	1400	1395	1395	1380	1360								
	5-Ton A/C Cooling	1750	0-1.0‡	1745	1750	1750	1750	1745	1740	1745	1745	1740	1735									
6-Ton A/C Cooling	2100	0-1.0	2055	2070	2080	2085	2095	2100	2100	2100	2090	2065										
Maximum	2200	0-1.0	2175	2190	2200	2200	2200	2200	2200	2200	2200	2180	2160									

58CVA/CVX

* Actual external static pressure (ESP) can be determined by using the fan laws (CFM² proportional to ESP); such as, a system with 1180 CFM at 0.5 ESP would operate at cooling airflow of 1050 CFM at 0.4 ESP and low-heating airflow of 735 CFM at 0.19 ESP.

† Low heat CFM when low-heat rise adjustment switch (SW1-3) and comfort/efficiency adjustment switch (SW1-4) on control center are OFF.

‡ Ductwork must be sized for high-heating CFM within the operational range of ESP.

** Wattage data provided is for the circulating blower with bottom return and does not include draft inducer, accessories, or gas controls.

†† Operation within the blank areas of the chart is not recommended because high-heat operation will be above 1.0 ESP.

*** All airflows on 110 size furnace are 5 percent less on side return only installations.

AIR DELIVERY- POWER DRAW (WATTS)**

Unit Size	Operating Mode	CFM Airflow Setting	External Static Pressure Range*	External Static Pressure (ESP)											
				0.1	0.2	0.3	0.4	0.5	0.6	0.7	0.8	0.9	1.0		
070-12				POWER DRAW (WATTS)**											
††	Low Heat	735 (615)†	0-0.50	84	100	119	133	148							
	High Heat	1180 (1060)†	0-1.0	227	256	287	318	347	381	407	435	462	485		
	†	1-1/2 Ton Cooling	525	0-0.50‡	48	63	74	86	98						
	†	2-Ton A/C Cooling	700	0-0.50‡	75	90	108	121	135						
		2-1/2 Ton A/C Cooling	875	0-1.0‡	123	145	163	183	202	221	238	257	275	297	
		3-Ton A/C Cooling	1050	0-1.0‡	181	205	226	253	278	302	326	350	371	392	
		3-1/2 Ton A/C Cooling	1225	0-1.0	254	289	320	355	384	416	444	472	495	515	
		Maximum	1400	0-1.0	381	413	462	490	527	556	586	607	616	608	
090-16															
††	Low Heat	985 (825)†	0-1.0	115	144	170	197	224	251	279	306	334	359		
	High Heat	1210 (1090)†	0-1.0	187	216	245	280	314	343	375	407	435	463		
	†	1-1/2 Ton A/C Cooling	525	0-0.50‡	45	61	77	93	107						
	†	2-Ton A/C Cooling	700	0-0.50‡	61	78	96	118	138						
		2-1/2-Ton A/C Cooling	875	0-1.0‡	87	110	136	159	183	207	229	254	283	304	
		3-Ton A/C Cooling	1050	0-1.0‡	127	159	185	214	242	271	301	329	356	384	
		3-1/2 Ton A/C Cooling	1225	0-1.0	191	223	246	283	312	349	378	412	441	469	
		4-Ton A/C Cooling	1400	0-1.0	267	304	342	382	424	463	495	531	558	587	
	Maximum	1600	0-1.0	390	434	483	526	568	608	617	623	630	625		
110-20***															
††	Low Heat	1320 (1110)†	0-1.0	188	237	277	332	376	419	466	507	549	589		
	High Heat	1475 (1330)†	0-1.0	264	311	357	407	453	501	547	597	633	683		
	†	2-Ton A/C Cooling	700	0-0.50‡	65	86	113	135	159						
	†	2-1/2 Ton A/C Cooling	875	0-0.50‡	84	117	143	171	202						
		3-Ton A/C Cooling	1050	0-0.50‡	126	159	190	220	269						
		3-1/2 Ton A/C Cooling	1225	0-1.0‡	161	197	247	288	335	373	415	465	505	545	
		4-Ton A/C Cooling	1400	0-1.0‡	228	270	316	371	415	456	503	554	589	635	
		5-Ton A/C Cooling	1750	0-1.0‡	373	443	504	555	614	670	727	779	830	888	
	6-Ton A/C Cooling	2100	0-1.0	663	732	803	860	922	978	1027	1069	1111	1146		
	Maximum	2200	0-1.0	778	840	907	958	1022	1079	1133	1168	1191	1175		
135-22															
††	Low Heat	1700 (1430)†	0-1.0	321	371	430	469	509	562	608	666	706	757		
	High Heat	1915 (1725)†	0-1.0	429	476	542	601	658	730	778	832	902	944		
	†	2-Ton A/C Cooling	700	0-0.50‡	61	83	107	128	149						
	†	2-1/2 Ton A/C Cooling	875	0-0.50‡	76	107	134	160	187						
		3-Ton A/C Cooling	1050	0-0.50‡	103	135	174	208	240						
		3-1/2-Ton A/C Cooling	1225	0-1.0‡	131	174	210	253	289	336	374	423	459	511	
		4-Ton A/C Cooling	1400	0-1.0‡	201	250	283	330	376	410	453	491	533	565	
		5-Ton A/C Cooling	1750	0-1.0‡	343	400	450	491	535	584	630	681	730	779	
	6-Ton A/C Cooling	2100	0-1.0	573	631	705	762	827	890	943	998	1044	1091		
	Maximum	2200	0-1.0	656	725	803	863	928	984	1047	1087	1126	1142		
155-22															
††	Low Heat	1715 (1440)†	0-1.0	310	366	402	443	486	525	580	621	668	719		
	High Heat	1970 (1775)†	0-1.0	442	493	547	604	655	720	770	826	879	932		
	†	2-Ton A/C Cooling	700	0-0.50‡	60	79	105	126	147						
	†	2-1/2 Ton A/C Cooling	875	0-0.50‡	73	97	128	154	178						
		3-Ton A/C Cooling	1050	0-0.50‡	96	122	153	196	226						
		3-1/2 Ton A/C Cooling	1225	0-1.0‡	121	166	201	244	277	314	358	400	441	491	
		4-Ton A/C Cooling	1400	0-1.0‡	188	225	266	299	345	389	423	462	498	540	
		5-Ton A/C Cooling	1750	0-1.0‡	322	367	422	466	498	546	598	653	693	740	
	6-Ton A/C Cooling	2100	0-1.0	500	557	620	691	743	814	864	936	985	1027		
	Maximum	2200	0-1.0	592	673	746	811	885	935	994	1026	1102	1129		

58CVA/CVX

* Actual external static pressure (ESP) can be determined by using the fan laws (CFM² proportional to ESP); such as, a system with 1180 CFM at 0.5 ESP would operate at cooling airflow of 1050 CFM at 0.4 ESP and low-heating airflow of 735 CFM at 0.19 ESP.

† Low heat CFM when low-heat rise adjustment switch (SW1-3) and comfort/efficiency adjustment switch (SW1-4) on control center are OFF.

‡ Ductwork must be sized for high-heating CFM within the operational range of ESP.

** Wattage data provided is for the circulating blower with bottom return and does not include draft inducer, accessories, or gas controls.

†† Operation within the blank areas of the chart is not recommended because high-heat operation will be above 1.0 ESP.

*** All airflows on 110 size furnace are 5 percent less on side return only installations.

Dimensions

58CVA/CVX

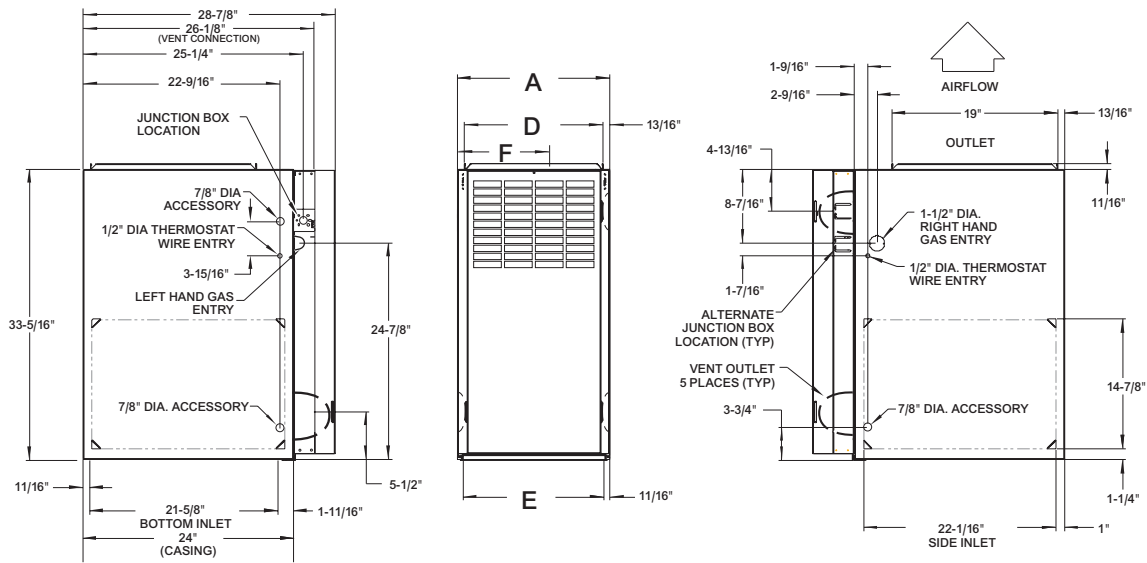

A03060

- NOTES:
- Two additional 7/8-in. dia. knockouts are located in the top plate.
 - Minimum return-air openings at furnace, based on metal duct. If flex duct is used, see flex duct manufacturer's recommendations for equivalent diameters.
 - Minimum return-air opening at furnace.
 - For 800 CFM-16-in. round or 14-1/2 x 12-in. rectangle.
 - For 1200 CFM-20-in. round or 14-1/2 x 19-1/3 in. rectangle.
 - For 1600 CFM-22-in. round or 14-1/2 x 22-1/16-in. rectangle.
 - For airflow requirements above 1800 CFM, see Air Delivery table in Product Data literature for specific use of single side inlets. The use of both side inlets, a combination of 1 side and the bottom, or the bottom of single side inlets. The use of both side inlets, a combination of 1 side and the bottom, or the bottom only will ensure adequate return air openings for airflow requirements above 1800 CFM.

58CVA/CVX UNIT SIZE	A CABINET WIDTH (IN.)	D SUPPLY WIDTH (IN.)	E BOTTOM RETURN WIDTH (IN.)	F C.L. TOP & BOTTOM VENT OUTLET (IN.)	VENT CONNECTION SIZE (IN.) (see notes 1 & 2)	MEDIA CABINET SIZE (IN.)
070-12	14-3/16	12-9/16	12-11/16	9-5/16	4	16
090-16	17-1/2	15-7/8	16-1/8	11-9/16	4	16
110-20	21	19-3/8	19-1/2	13-5/16	4	20
135-22	24-1/2	22-7/8	23	15-1/16	4 (note 1)	24
155-22	24-1/2	22-7/8	23	15-1/16	4 (note 1)	24

- 135 and 155 size furnaces require five-inch vents. Use a 4-5 in. vent adapter between furnace and vent stack.
- See Installation Instructions for complete installation requirements.

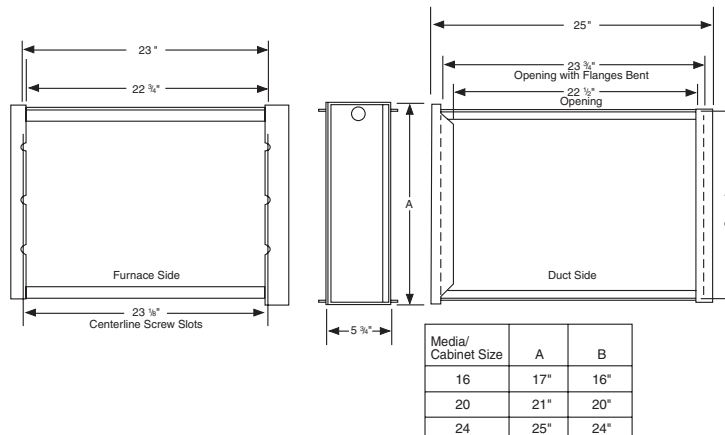

Typical wiring schematic

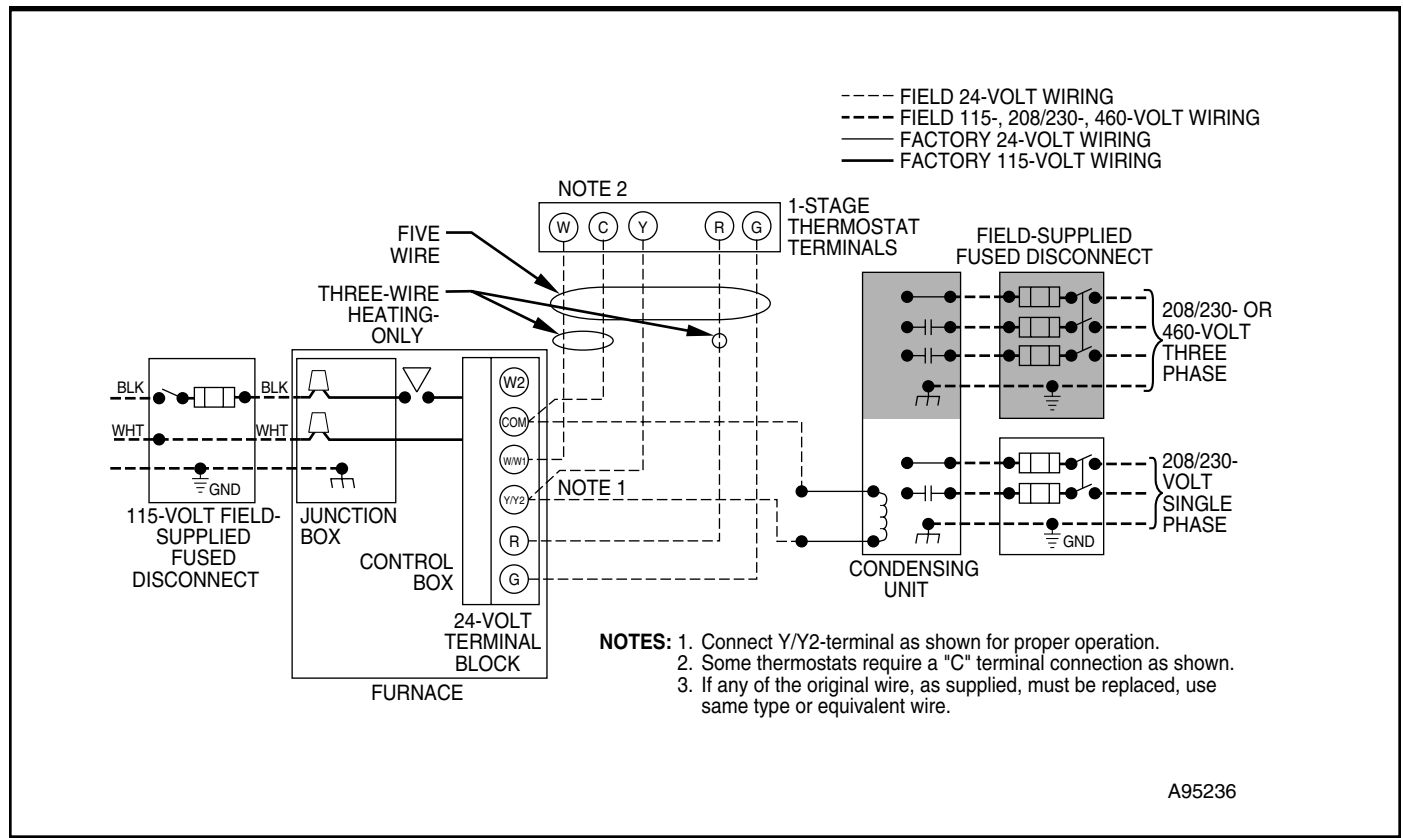

58CVA/CVX

Electrical data

UNIT SIZE	VOLTS-HERTZ-PHASE	OPERATING VOLTAGE RANGE		MAXIMUM UNIT AMPS	MAXIMUM WIRE LENGTH (FT)‡	MAXIMUM FUSE OR CKT BKR AMPS†	MINIMUM WIRE GAGE
		Maximum*	Minimum*				
070-12	115-60-1	127	104	9.0	30	15	14
090-14	115-60-1	127	104	9.6	29	15	14
110-20	115-60-1	127	104	15.1	29	20	12
135-22	115-60-1	127	104	14.9	30	20	12
155-20	115-60-1	127	104	15.0	29	20	12

* Permissible limits of the voltage range at which unit operates satisfactorily.

† Time-delay type is recommended.

‡ Length shown is as measured one way along wire path between unit and service panel for maximum 2 percent voltage drop.

Typical Installation

58CV/A/CVX

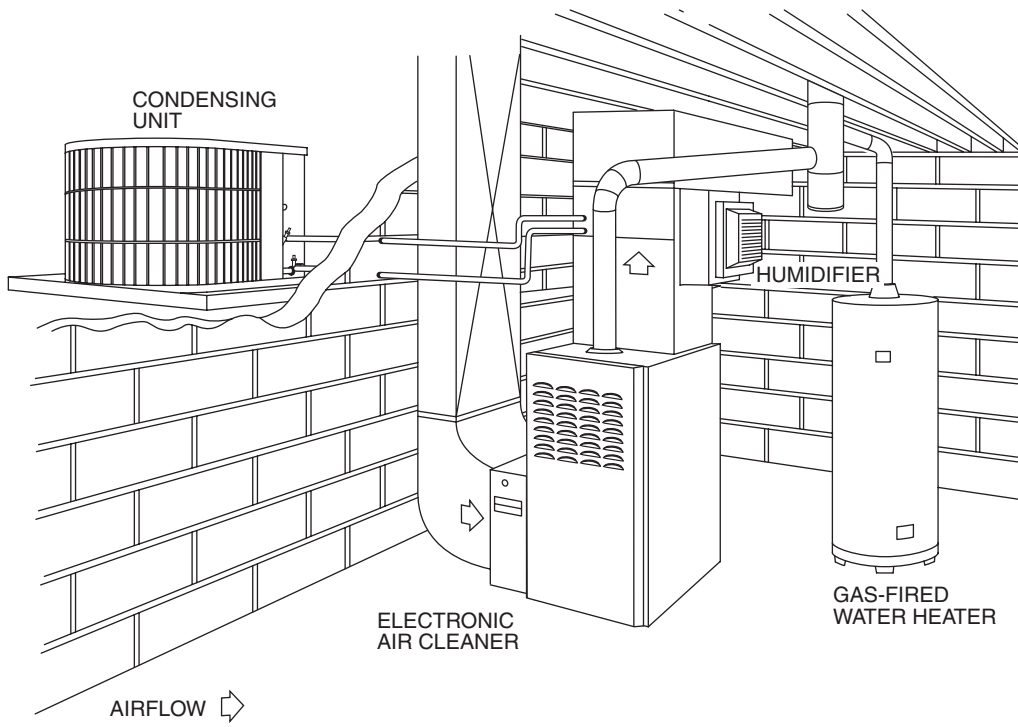

A02184

Guide Specifications

Gas Furnace 58CVA/CVX

General

SYSTEM DESCRIPTION

Furnish a _____ Variable speed gas-fired two stage furnace for use with natural gas or propane (factory authorized conversion kit required for propane); furnish cold air return plenum; furnish external medial cabinet for use with accessory media filter or standard filter.

QUALITY ASSURANCE

Unit will be designed, tested and constructed to the current ANSI Z 21.47/CSA 2.3 design standard for gas-fired central furnaces. Unit will be 3rd party certified by CSA to the current ANSI Z 21.47/CSA 2.3 design standard for gas-fired central furnaces.

Unit will carry the CSA Blue Star® and Blue Flame® labels.

Unit efficiency testing will be performed per the current DOE test procedure as listed in the Federal Register.

Unit will be certified for capacity and efficiency and listed in the latest GAMA Consumer's Directory of Certified Efficiency Ratings.

Unit will carry the current Federal Trade Commission Energy Guide efficiency label.

DELIVERY, STORAGE AND HANDLING

Unit shall be shipped as single package only and is stored and handled per unit manufacturer's recommendations.

WARRANTY (for inclusion by specifying engineer)

U.S. and Canada only. Warranty certificate available upon request.

Products

EQUIPMENT

Components shall include: slow-opening two-stage dual fuel gas valve to reduce ignition noise, regulate gas flow, with electric switch gas shut-off; flame proving sensor, hot surface igniter, dual pressure switch assembly, flame rollout switch, ICM blower and two speed inducer assembly, 40va transformer; low-voltage (heating) (heating/cooling) thermostat.

Blower Wheel and ECM Blower Motor

Galvanized blower wheel shall be centrifugal type, statically and dynamically balanced. Blower motor of ECM type shall be permanently lubricated with sealed ball bearings, of _____hp, and supplies delivers requested airflow CFM as defined by signals received from EZ-SELECT airflow control when 24VAC motor inputs are provided. Blower motor shall be direct drive and soft mounted to the blower scroll to reduce variation transmission.

Filters

Furnace shall have reusable-type filters. Filter shall be _____in (x) _____in. An accessory high efficiency Media Filter is available as an option. _____Media Filter.

Casing

Casing shall be of .030 in. thickness minimum, pre-painted galvanized steel.

Two-Speed Inducer Motor

Two-Speed Inducer motor shall be of two-speed design being soft mounted to assembly to reduce vibration transmission.

Flame Rollout Switch

Flame Rollout Switch shall be factory installed near burner area to further reduce the possibility of a stuck gas valve or failed inducer motor.

Heat Exchangers

Primary Heat exchangers shall be 4-Pass 20 gage corrosion resistant aluminized steel of fold-and-crimp sectional design when applied operating under negative pressure.

Controls

Controls shall include a micro-processor based integrated electronic control board with at least 11 service troubleshooting codes displayed via diagnostic flashing LED light on the control, a self-test feature that checks all major functions of the furnace, and a replaceable automotive-type circuit protection fuse. Multiple operational settings available with the EZ-SELECT fan control, including, separate blower speeds for low heat, high heat, low cooling, high cooling and continuous fan. Continuous fan speed may be adjusted from the thermostat. Cooling airflow will be selectable between 350 or 400 CFM per ton of air conditioning. Features will also include temporary reduced airflow in the cooling mode for improved dehumidification when an Infinity Control or Thermidistat® is selected as the thermostat.

OPERATING CHARACTERISTICS

Heating Capacity shall be _____ Btuh input; _____ Btuh output capacity.

Fuel Gas Efficiency shall be 80% AFUE.

Air delivery shall be _____ cfm minimum at 0.50 in. wg external static pressure.

Dimensions shall be: depth _____ in.; width _____ in.; height _____ in. (casing only). Height shall be _____ in. with A/C coil and _____ in. overall with plenum.

ELECTRICAL REQUIREMENTS

Electrical supply shall be 115 volts, 60 Hz, single-phase (nominal). Minimum wire size shall be _____ AWG; maximum fuse size or HACR-type designated circuit breaker shall be _____ Amps.

SPECIAL FEATURES

Refer to section of the product data sheet identifying accessories and descriptions for specific features and available enhancements.